

Socket Welding							
Nom. Pipe Size	B	C		D	A	G (Min)	J (Min)
		(Avg)	(Min)				
1/8	10.8	3.18	3.18	6.9	11.0	2.41	9.5
1/4	14.2	3.78	3.30	9.3	11.0	3.02	9.5
3/8	17.6	4.01	3.50	12.6	13.5	3.20	9.5
1/2	21.8	4.67	4.09	15.8	15.5	3.73	9.5
3/4	27.2	4.90	4.27	21.0	19.0	3.91	12.5
1	33.9	5.69	4.98	26.7	22.5	4.55	12.5
1 1/4	42.7	6.07	5.28	35.1	27.0	4.85	12.5
1 1/2	48.8	6.35	5.54	40.9	32.0	5.08	12.5
2	61.2	6.93	6.04	52.5	38.0	5.54	16.0

## SOCKET WELD CARBON STEEL 3000LB 45DEG ELBOW

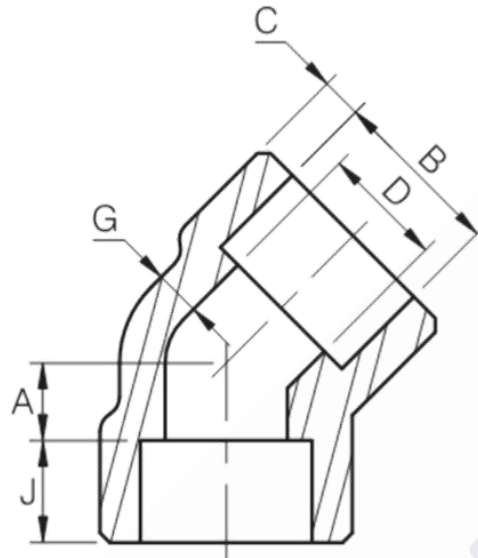

Socket Welding							
Nom. Pipe Size	B	C		D	A	G (Min)	J (Min)
		(Avg)	(Min)				
1/8	10.8	3.18	3.18	6.9	8.0	2.41	9.5
1/4	14.2	3.78	3.30	9.3	8.0	3.02	9.5
3/8	17.6	4.01	3.50	12.6	8.0	3.20	9.5
1/2	21.8	4.67	4.09	15.8	11.0	3.73	9.5
3/4	27.2	4.90	4.27	21.0	13.0	3.91	12.5
1	33.9	5.69	4.98	26.7	14.0	4.55	12.5
1 1/4	42.7	6.07	5.28	35.1	17.5	4.85	12.5
1 1/2	48.8	6.35	5.54	40.9	20.5	5.08	12.5
2	61.2	6.93	6.04	52.5	25.5	5.54	16.0